

The A2-07 SC series was be designed for a single nozzle application. Our modular single cavity work-horse series, simplicity for easy to use and service, modularity to suit your requirement.

All modular elements for this A2-07 SC series is the same as used for our A3 All-In-One series. To find nozzle that suit your parts' gate requirements, simply select nozzle length and front style using our nozzle guide.

Nozzle bore machining should follow the instructions in drawing 1. Pay attention to length L1. L1 is calculated by adding the nozzle length to the nozzle compensate for heat losses that occur between the nozzle and mould steel.

When using the A2-07 SC in a single drop application, make sure that the back of the nozzle does not touch the locating ring. Contact with the locating ring will allow heat from the nozzle to dissipate into the mold.

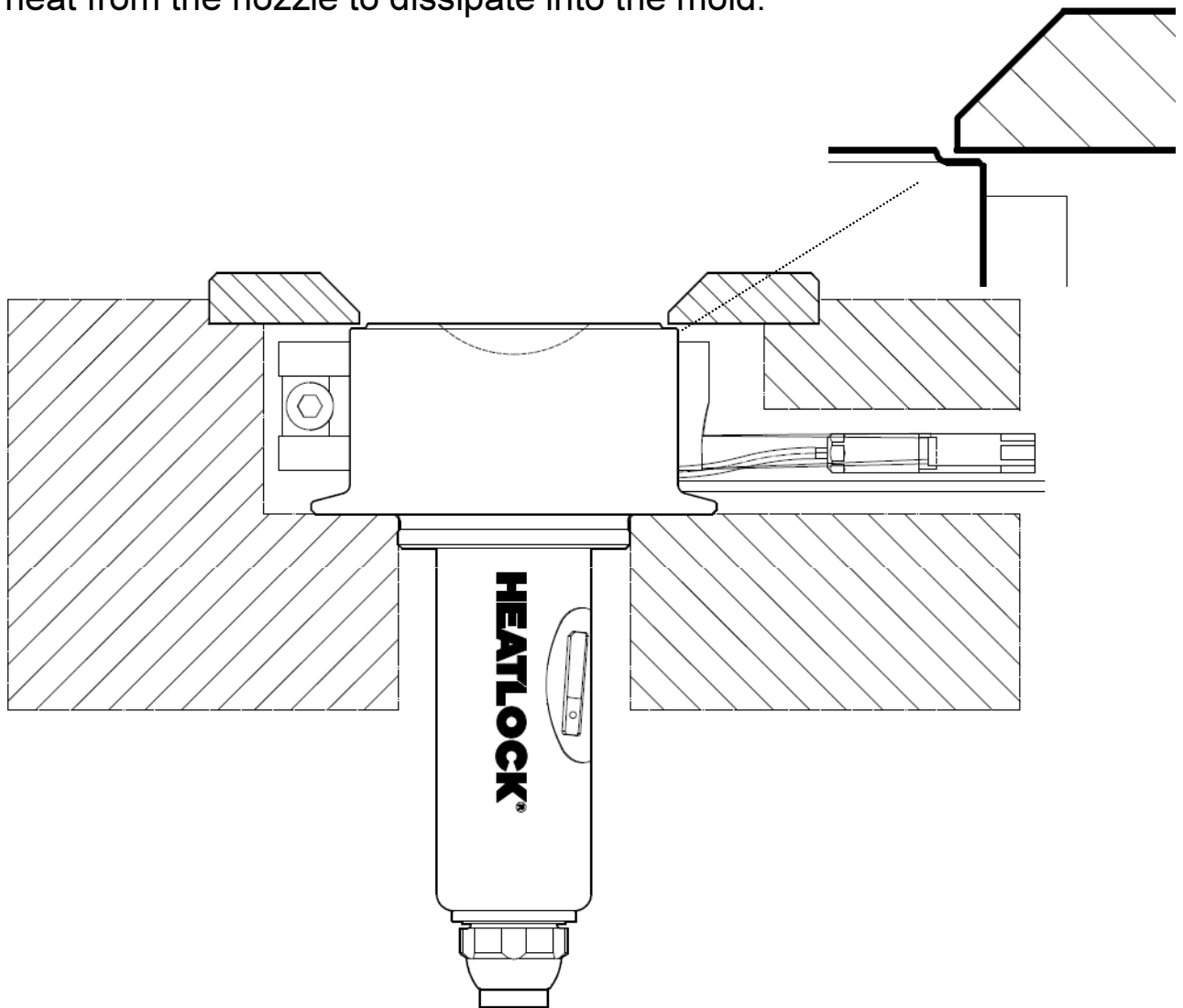

If the force at which the machine nozzle is pressed against the sprue bushing is greater than that caused by the injection force on the front area of the bushing, no additional force is required to keep the bushing in place axially.

Wiring instructions

Attention: Only connectors designed to match the temperature controller are to be used.

10 Pin Connector,
HEATLOCK connections as per illustration at right:

ZONE 1

1. Connect (1)(2) with heater.
2. Connect T/C wire (+black) with (6).
3. Connect T/C wire (-white) with (7).

ZONE2

4. Connect (3)(4) with heater.
 5. Connect T/C wire (+black) with (8).
 6. Connect T/C wire (-white) with (9).
7. Connect mould with ground wire & insert.

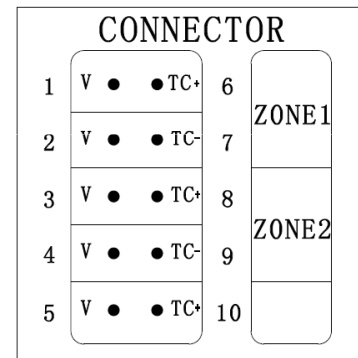
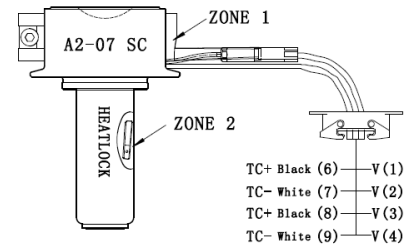

Instructions for replacement of HP heater

Attention: For best performance use HEATLOCK original components.

Disassembly:

Open the buckle, and take off the HP heater from nozzle body;

Assembly:

1. Make sure the buckle is open.



Open buckle direction

2. Put the HP heater on nozzle body, and close the buckle.

HP heater should be same position with the chamfer of body.



HP heater exit should be at the bottom of heater slot.



*Please make sure the heater can not move after locked the buckle.

Finish the HP heater replacement.

Instructions for replacement of spare part T/C

Attention: For best performance use HEATLOCK original components.

Disassembly:

1. Open the buckle, and take off the HP heater from nozzle body;



2. Open the lug on top;



3. Then open the lug at the end of heater;



4. Take out the T/C slowly;

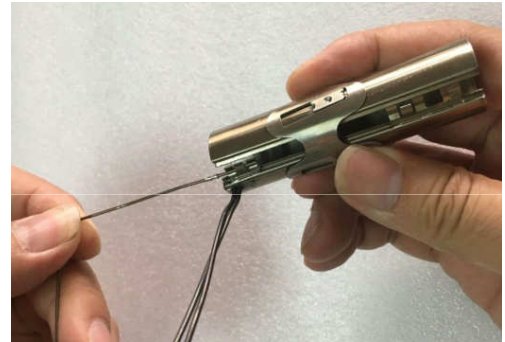

Assembly:

1. Slide the T/C up to the stop position.

stop position



2. Closed the lug over the position-ring for fixation.



position-ring



Make sure the position-ring is under the lug to keep the T/C in the right position.

3. Closed other lug at end of HP heater.



Finish the T/C replacement.

If there are any problems encountered during assembly, please call :(86)757-2991 5868.