

A2-XL

Assembly Instruction

Features:

The maximum permitted contact force from Machine nozzle is 4-Mpa. The A2-XL series can be designed for a single nozzle application, or a multi-drop application utilizing a hot runner manifold.

The coil heater is designed to provide uniform heat distribution along the length of the nozzle. A concentration of heater windings at both ends of the nozzle compensate for heat losses that occur between the nozzle and mould steel.

Assembly method:

Nozzle bore machining should follow the instruction in drawing. Pay attention to length LA1. LA1 is calculated by adding the nozzle length to the nozzle theoretical heat expansion. Nozzle heat expansion values may be found in table 1.

when using the A2-XL in a single drop application, make sure that the back of the nozzle does not touch the locating ring. Contact with the locating ring will allow heat from the nozzle to dissipate into the mold.

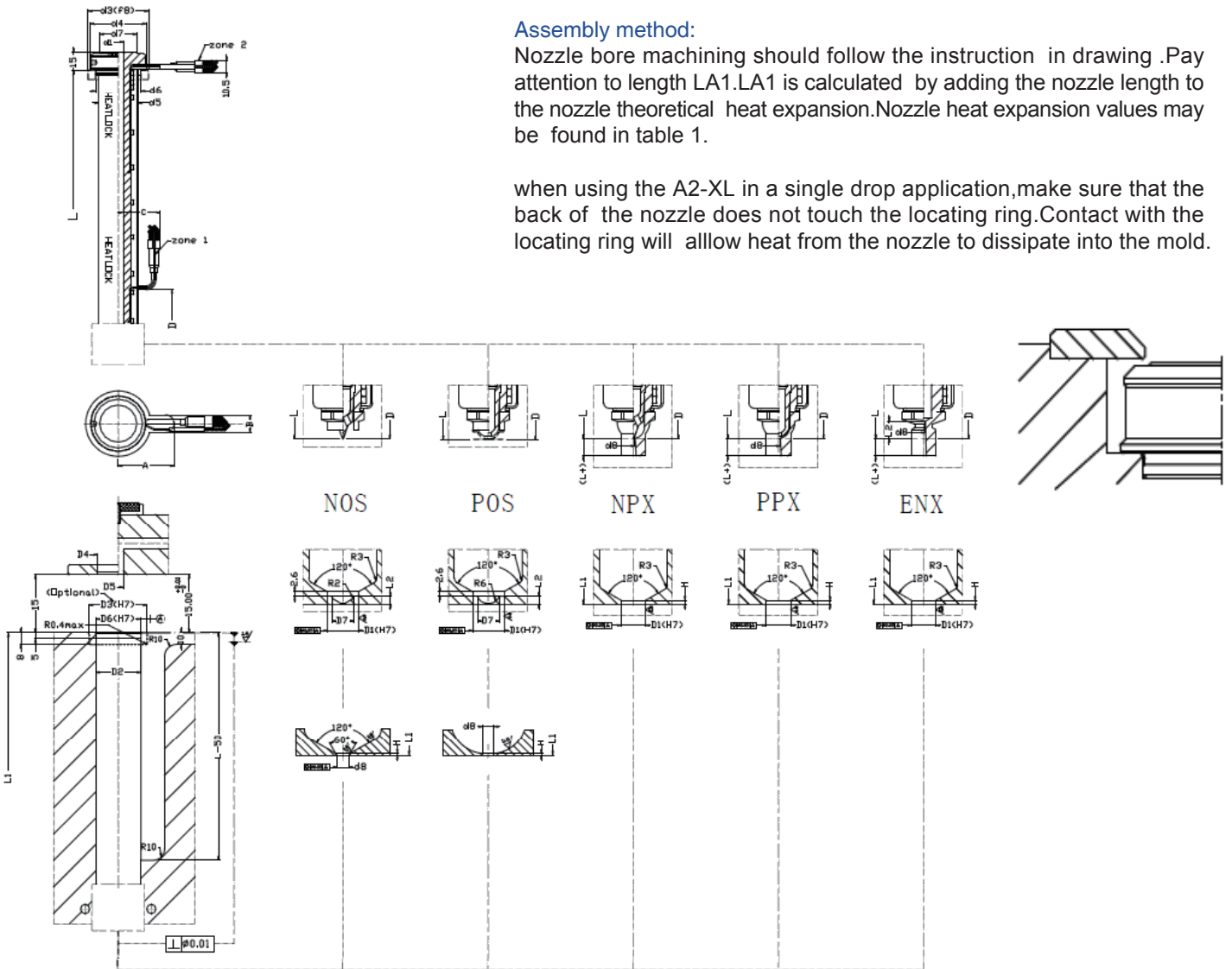

A2-XL Series

Size	L	L(+)			d1	d4	d7	d8			L2			H					D1					D2	D3	D4	D5	D6	D7	A	B	C	D
	All	ENX	NPX	PPX	All	All	All	ENX	NPX	PPX	ENX	NOS	POS	ENX	NOS	POS	NPX	PPX	ENX	All	All	All	All	All	All	All	All	All	All				
Size3	200<L<500	10	10		10	48	32	2	≥2	10	4.4			2	0.3				18	14			39	T50	34	9	39	12.5	40	15	35	65	
Size4	250<L<500	20	15		17	52	34.5	3	≥2	10	5.4			2	0.3				26	20			44	T54	36.5	14	44	18	45	15	40	65	

*D3尺寸: T is Titanium ring

Length of nozzle

Heat expansion of the nozzle must be considered in order to ensure minimum vestige on the part. Expansion values (X.xx) various temperatures and nozzle (size 4) lengths are illustrated in the table below:

Length Expansion (L1 = L + X.XX) (mm)

T \ L	250	300	350	400	450	500
200	0.65	0.77	0.89	1.01	1.13	1.25
250	0.85	1.00	1.16	1.31	1.47	1.62
300	1.08	1.27	1.47	1.67	1.86	2.06
350	1.18	1.39	1.60	1.82	2.03	2.25

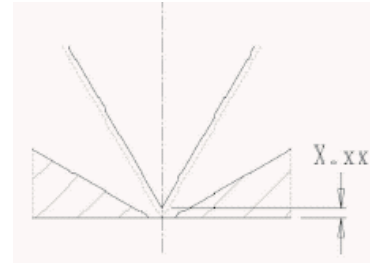

Gate diameter

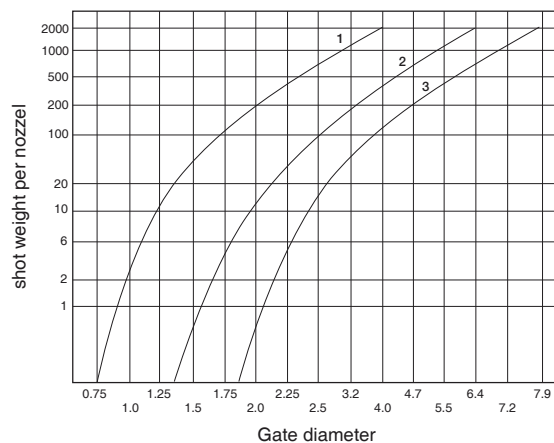

- 1. low viscosity :PS PE PP
- 2. medium viscosity :ABS SAN PA POM
- 3. high viscosity: PC PMMA

Note : for filled materials, gate diameter should increase 20%.

The diagram above is a guideline for gate diameters needed for various plastics and shot weights.

Note: If the gate diameter is too small, an unnecessary high bushing temperature will have to be set for the gate not to freeze between shots. The suggested figures are approximate. Gate dimensions may be influenced by the shape of the part and the design of the mould, etc.

The balance between shot weight, injection speed, mould temperature, temperature opposite the gate, cooling around the gate, and injection pressure are all factors that affect gate size. A small gate freezes quicker than a large one. When injection moulding with very short cycle times and short injection times, it may be necessary to design gate cooling so that the gate area does not overheat.

If the sprue bushing is feeding a runner which has a gate into a cavity, it may be suitable to make the bushing gate larger than actual necessary in order to reduce pressure drop and shear.

If an electric sprue bushing is used, this will reduce the length of flow in cold steel therefore allowing the reduction of the cross section of the cold runner. This is important in order to get the shortest possibility of cycle time. Start with a smaller gate than indicated in the table.

Wiring instruction

Attention: Only connectors designed to match the temperature controller are to be used.
Heater and T/C wiring must not be connected in parallel.

10 pin connector

HEATLOCK connections as per illustration at right:

1. Zone 1 Connect (1)(2) with heater
2. Connect T/C wire (black/red) with (6)
3. Connect T/C wire (white/blue) with (7)
4. ZONE2 Connect (3)(4) with heater
5. Connect T/C wire (black/red) with (8)
6. Connect T/C wire (black/red) with (9)
7. Connect mould with ground wire & insert

Instructions for replacement of heater or T/C

Attention: For best performance use HEATLOCK original components.

Disassembly:

1. Open lock ring.
2. Remove reflector.
3. Carefully slide heater off of nozzle.
4. Remove T/C.

Assembly

opposite processing to disassembly

If necessary, replace T/C by inserting new T/C into small hole at the end of slot. Ensure that the tip is in full contact with the bottom of the bore before bending the T/C along the slot. Install heater onto nozzle ensuring that the T/C is not displaced. Bundle the heater and T/C together using high temperature adhesive tape.

Nozzle assembly torque	
Size No.	Torque(N)
size 3	25
size 4	30

*If there are any problems encountered during assembly, please call (86) 769-8382 5600.

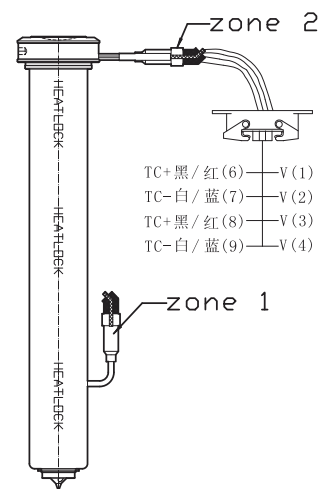

CONNECTOR

6	TC +	1	ZONE 1
7	TC -	2	
8	TC +	3	ZONE 2
9	TC -	4	
10	TC +	5	

