

HEATLOCK® PPB3..., PIN POINT BUSH

Instructions for installations.

Max permitted contact force from machine nozzle: 4 Mp.

Boring dimensions

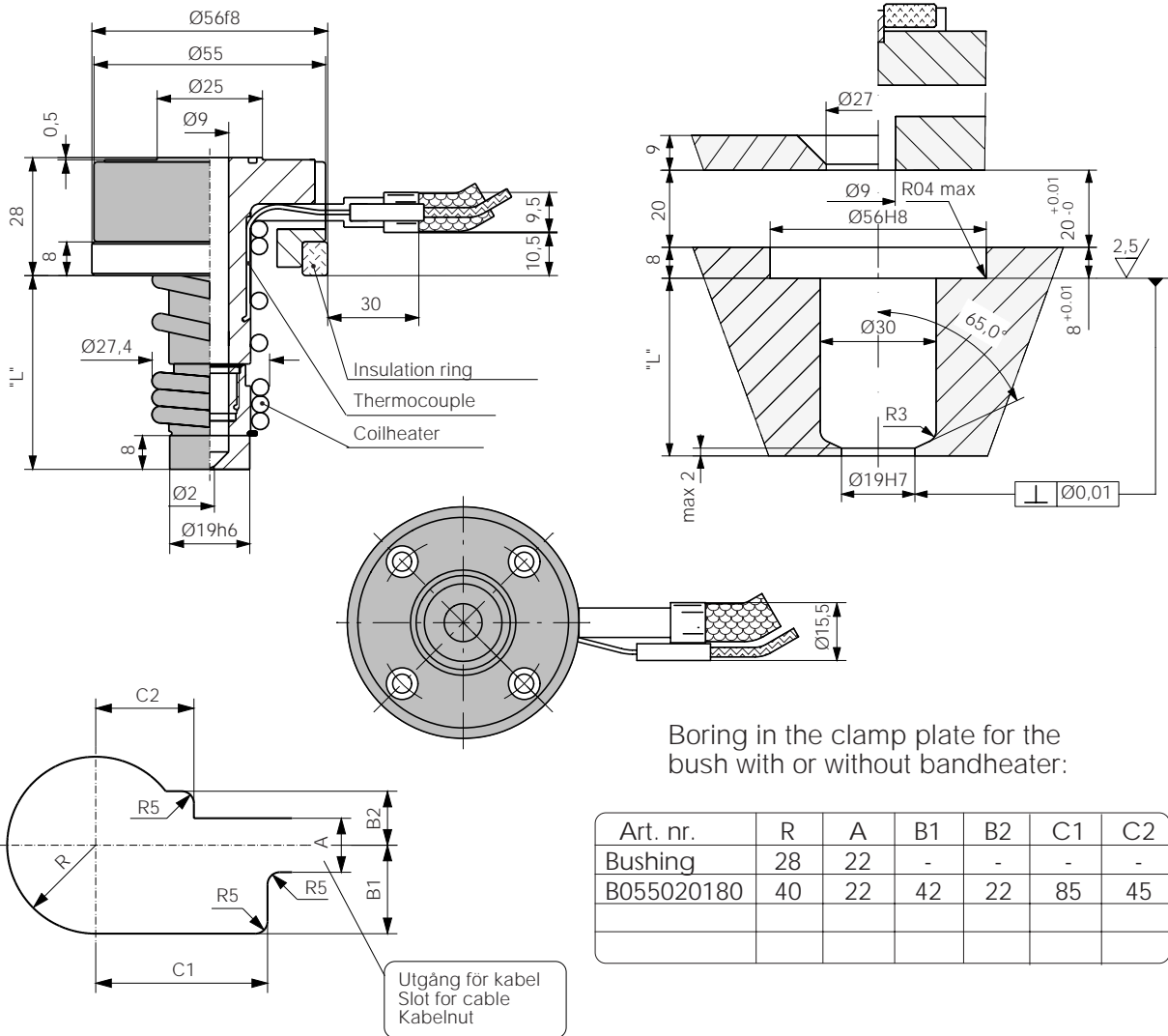

Boring in the clamp plate for the bush with or without bandheater:

Art. nr.	R	A	B1	B2	C1	C2
Bushing	28	22	-	-	-	-
B055020180	40	22	42	22	85	45

When designing the bushing heaters we took every possible step to make the heat distribution along the bushing as even as possible. We have thus concentrated the wattage at both ends in order to compensate for heat losses which are the result of metallic contact between bushing and mould. The ceramic insulation is of course also highly important for uniform temperature distribution in the bushing.

When temperatures of 250–260 °C and above are needed it may be advantageous to install a heater band at the back end. This is also the case when shearsensitive materials are to be moulded.

Note: This element must be connected to its own special manual controller and must not be connected in parallel with the spiral element and its thermocouple.

If the bushing is installed as shown in the diagram, all cables will be protected from plastic. If possible there shall be no contact between the back end of the bushing and the guide ring of the mould. Such contact will cause a heavy drop in temperature at the back end of the bushing. If the force at which the machine nozzle is pressed against the sprue bushing is greater than that caused by the injection force on the front area of the bushing, nothing is needed to keep bushing in place axially. The bushing can then be installed as shown in the diagram below. Max permitted contact

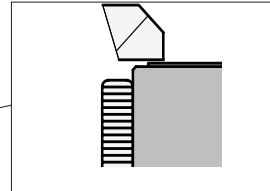
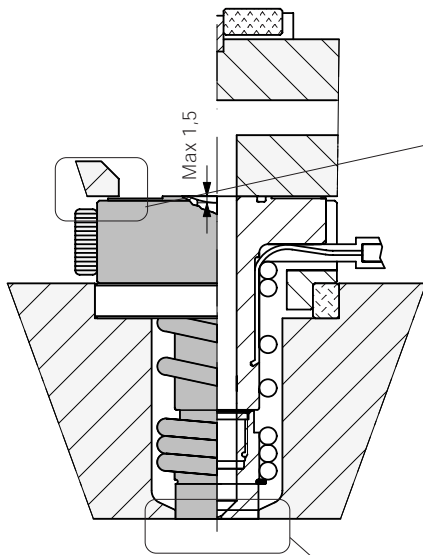

force from machine nozzle: 4 Mp.
 If a support is needed to fix the bushing axially the contact area must be as small as possible. The support area should preferably be as far as possible from the centre of the bushing. (Not on the flange.)
 Preferably an insulation ring part No. KE05604408 shall be placed between the back support and the surface of the bushing.

Colour code for thermocouple wires.

Black (red) wire + (Iron) Vit (blue) wire —.

The connector sleeve of the thermocouple has a max. temperature resistance of 240 °C.

Fitting of the front end of the bushing.

A certain amount of cooling is needed at front end. It must remain at a temperature low enough to make the plastic solidify. Too much cooling will however cause the plastic in the flow channel to be highly viscous further into the bushing. The contact surface at the front end may therefore have to be trimmed depending on, for example, temperature wanted and cycle time.

Length of contact at front end can usually be 2mm. For high temperature plastic and for long cycle time a shorter length may be needed (down to about 0,75mm). The fit at the front end in the mould also has an influence on the temperature at that area. A hard fit gives more cooling then a loose one.

On injection moulding with fast-injecting materials it may sometimes be necessary to have a length of contact greater than 2 mm, so that sufficient heat can be carried away from the front face. This may mean increasing the temperature of the bushing during startup and reducing it in continuous operation.

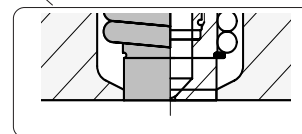

Length of the bushing.

When fitting the bushing into the mould it is essential to bear in mind that its length increases when it get hot. Approx. elongation of bushing at 200 °C

L46	approx. 0,10 mm
L66	approx. 0,17 mm
L86	approx. 0,22 mm
L116	approx. 0,27 mm
L146	approx. 0,38 mm
L176	approx. 0,46 mm

Size of gate.

On delivery is the gate 1 mm. Outward cone is 3° per side.

When enlarging the gate, use as a starting point the hole that exists when you centre the bushing.

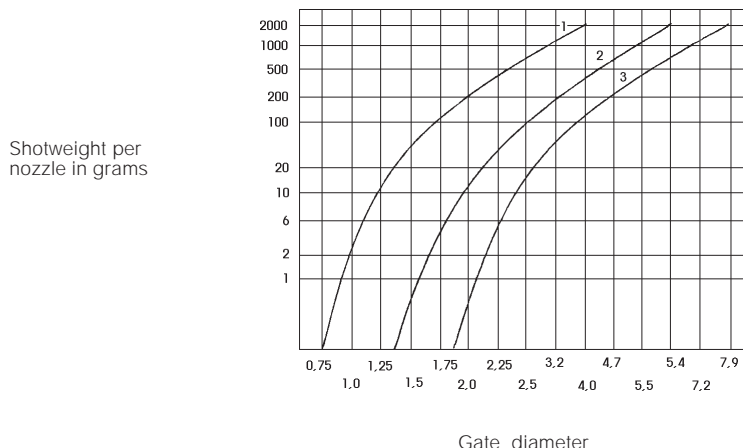

1. Low viscosity (PS, PE, PP).
2. Medium viscosity (ABS, SAN, PA, POM).
3. High viscosity (PC, PMMA, Noryl, PUR, reinforced plastics).

The diagram gives guideline figures for the gate diameter needed for different plastics and shot weights.

Note: If the gate diameter is too small, an unnecessarily high bushing temperature will have to be set for the gate not to freeze between shots.

Land length of gate.

With 1 mm gate diameter the length of the gate in the bushing is 0.6 mm. Owing to the shape of the internal flow channel at the gate hole, the length of the gate will increase when the diameter is increased. As a consequence of this the length of the gate residue will also increase.

If it is particularly important that the gate residue should be as short as possible, the gate length can be reduced by grinding away material from the front surface of the bushing. For minimum gate residue length, the length of the bushing can be reduced as shown for the stated diameters.

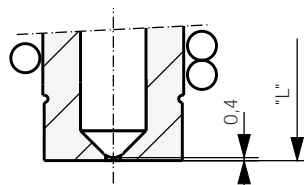

Gate diameter	Reduce length with
1,5 mm	0,06
2,0	0,13
2,5	0,23
3,0	0,36
3,5	0,52

If the bushing length is reduced as above, this must be taken into account when installing the bushing, otherwise the front plane of the bushing will be below the mould surface.

Instructions for changing the coilheater or thermocouple.

Disassembly

1. Take off the reflector (aluminium tube)
2. Unscrew the screws at the rear end.
3. Take off the flange.
4. Take off the lock ring at the front end.
5. Take off the spring that keeps thermocouple in place.
6. Take off the tape that keeps heater and thermocouple extensions together.
7. Depending on how hard spiral heater fits the pipe it can either be pulled of or "unscrewed". Unscrewing works easily if you push on the spiral heater extension which will open the spiral while at the same time opening the spiral at the other end with a suitable tool. The thermocouple must not follow if the spiral element is rotated or pulled off, since it may break. Treat thermocouple with great care. The tube is only 1 mm diameter.

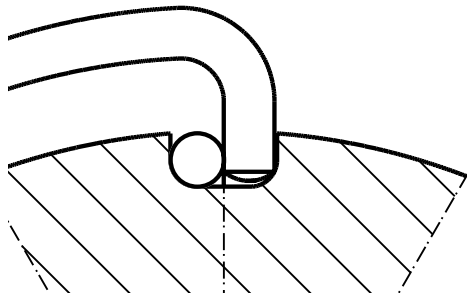

Assembly.

To be done in opposite order to disassembly.

If a new thermocouple is to be fitted it must be bent to fit the bushing. The tip of the thermocouple must be located where the groove ends, i.e. about half-way along the tube. Min. bending radius 3 mm.

Tighten the element so that the heating spiral makes contact with the tube.

If you have any questions about installing the bushing, please get in touch with us.

PPB3