

## SNN2/MNN2 Assembly Instruction

Max permitted contact force from machine nozzle: 4Mp.

### Installation:

Machine bore of nozzle in mould according to drawing 2, pay attention to length of nozzle plus heat expansion, coefficient is equal to length of L1 (refer to drawing 1)

When using NN2, make sure back of nozzle do not touch location ring, otherwise, a great deal of heat at the back of nozzle will dissipate (Refer to drawing 3).

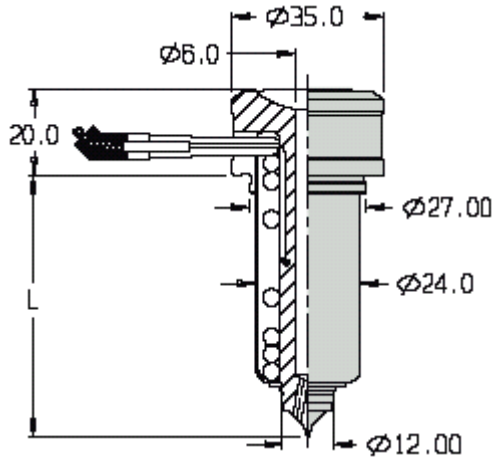

(drawing 1)

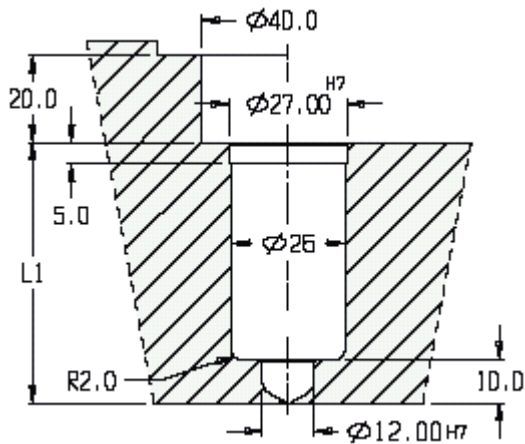
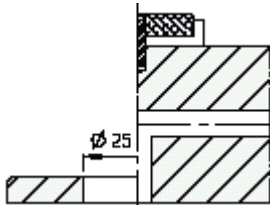

(drawing 2)

If the force at which the machine nozzle is pressed against the sprue bushing is greater than that caused by the injection force on the front area of the bushing, nothing is needed to keep bushing in place axially.

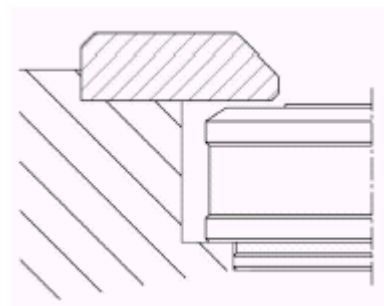
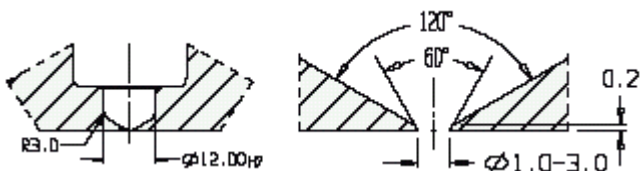

(drawing 3)

## Length of nozzle

In order to ensure minimum vestige on the part, consider nozzle's heat expansion.

Expansion coefficient (X.xx) in different temperature as below table:

溫度	長度	
	40	60
200	0.09	0.14
250	0.12	0.17
300	0.14	0.21
350	0.16	0.25

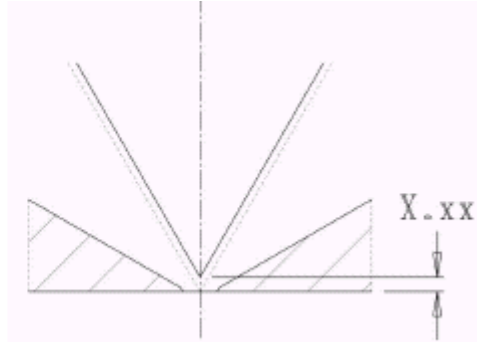

Gate diameter

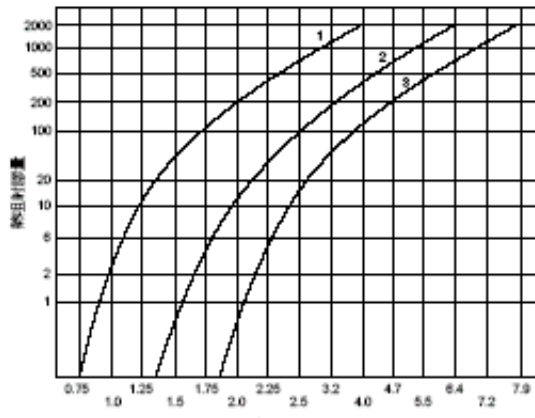

Gate diameter

1. low viscosity: PS PE PP
2. middle viscosity: ABS SAN PA POM
3. high viscosity: PC PMMA Noryl PUR

The diagram above gives a guideline figure for the gate diameter needed for different plastics and shot weights. Note: if the gate diameter is too small, an unnecessarily high bushing temperature will have to be set for the gate not to freeze between shots.

The suggested figures are approximate, gate dimension may be influenced by the shape of the part and the design of the mould etc.

The balance between shot weight, injection rate, tool temperature, temperature pattern opposite gate, cooling around gate and injection pressure are all factors that affect gate size, a small gate freezes quicker than a large gate. On injection moulding with very short cycle times and short injection times, it may be necessary to design gate cooling so that it does not overheat.

If the sprue bushing is feeding a runner which has a gate into a cavity, it may be suitable to make the bushing gate larger than actually necessary. This way pressure drop and shear will be reduced.

If an electric sprue bushing is used to feed a runner, this means that length of flow in cold steel has been reduced equivalent to the bushing length, due to this cross section, the runner can be made smaller than usual. This is important in order to get shortest possible cycle time.

Start with a smaller gate than indicated in the table.

## Wire instruction

Attention :the parts must connect with controller which match to parts, what's more, it's not allowed to connect with heater & T/C in parallel .

- 1.connect 6 pin insert (1)(2)with heater.
- 2.Connect T/C wire(black/red)with (4)
- 3.Connect T/C wire (white/blue)with (5)
- 4.Connect mould with ground wire & insert.

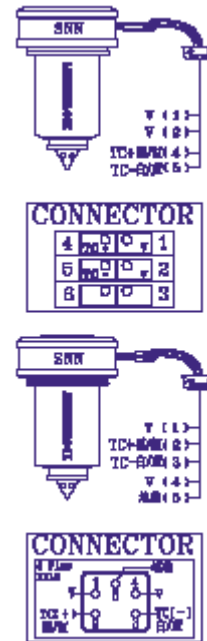

Instruction for replacing heater or T/C.

Attention: In order to avoid to affect normal function of nozzle, use LKMHEATLOCK original component .

Disassemble:

- 1.open lock ring.
- 2.Take off reflector.
- 3.Take down adhesive plaster coiled outside of heater & T/C.
- 4.Carefully take out off the heater.

Assemble:

If need replace T/C, insert new T/C to small hole at the end of slot, make sure it's tip must touch the bottom of bore, then bend it along slot and bundle it together with heater with adhesive plaster that can endure high temperature.

