

TGR TGS S2

mit Kalotte
with vestige
con calotta

TGR / TGS S2

Geeignet für alle Kunststoffe · Suitable for all plastics · Adatto per ogni tipo di plastica

- DE** > für flache Trennungen, inkl. Kalotte mit integrierter Abrisskante
> direkt einsetzbar! Keine Anpassungen erforderlich
> in Härte 60 HRC erhältlich
> erhältlich in runder (TGR) und eckiger (TGS) Ausführung

- EN** > for flat parting surfaces, including vestige with integrated cutting edge
> ready to use! No adjustments necessary
> available with hardness 60 HRC
> available in round (TGR) and square (TGS) versions

- IT** > per separazioni piatte, inclusa calotta con bordo di distacco integrato
> impiego diretto! Non sono necessari adattamenti
> disponibile in durezza 60 HRC
> disponibile in versione tonda (TGR) e squadrata (TGS)

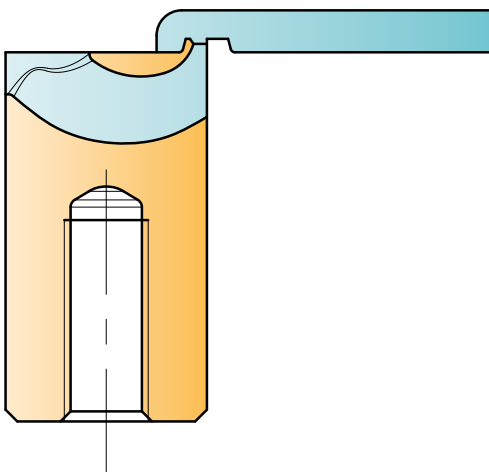

	TGR 6	TGR/TGS 8	TGR/TGS 10	TGR/TGS 12	TGR/TGS 14
 Anschnitt / gate point / punto d'iniezione	0.6	0,6 / 0,8	0,8 / 1,2 / 1,6	1,2 / 1,6 / 2,0	1,6 / 2,0 / 2,4 / 2,8
Ø Kanal / runner / canale	2.5	3	4	5	6
max. Schussgewichte (g) · max. shotweight (g) · pesi d'iniezione max. (g)					
NV	3	5	30	50	200
MV	2	4	20	35	120
HV	1	3	12	25	75

NV = niedrige Viskosität / low viscosity / bassa viscosità
MV = mittlere Viskosität / medium viscosity / media viscosità
HV = hohe Viskosität / high viscosity / elevata viscosità

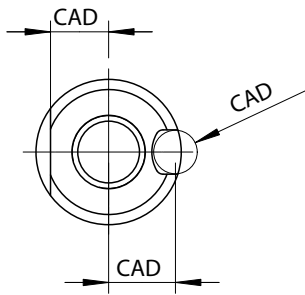

Mögliche Verdrehsicherung
Anti-rotation locking possibility
Possibilità di protezione antitorsione

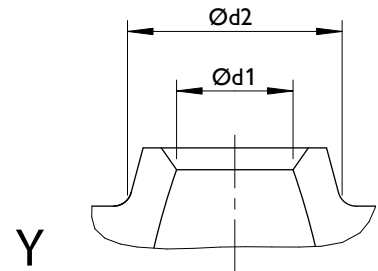
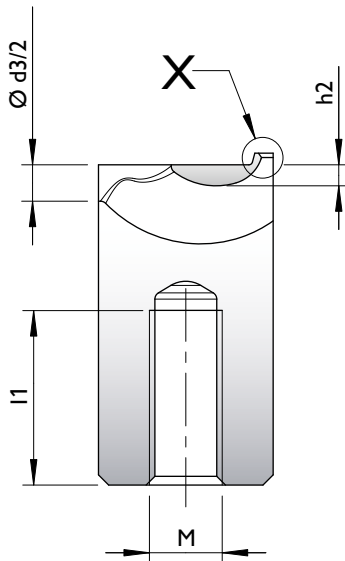
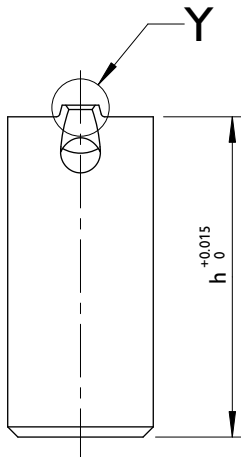
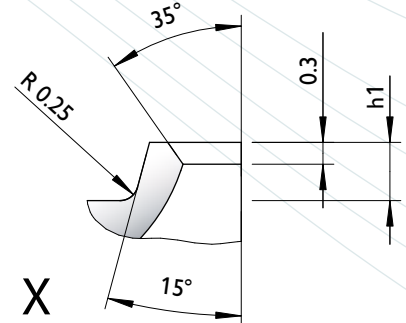

TGS	Typ	b	b1	d1	d2	d3	h	h1	h2	l1	l2	M	Version
	TGS8	8	6	0.6	1.9	3	22.0	0.6	1.1	13	3.25	4	S2
				0.8	2.1								
	TGS10	10	8	0.8	2.2	4	22.0	0.8	1.2	12	4	5	S2
				1.2	2.6								
				1.6	3.0								
	TGS12	12	10	1.2	2.6	5	22.0	0.8	1.40	11	5	5	S2
				1.6	3.0								
				2.0	3.4								
	TGS14	14	12	1.6	3.0	6	22.0	0.8	1.6	10	6	6	S2
				2.0	3.4								
				2.4	3.8								
				2.8	4.2								

TGR	Typ	d	d1	d2	d3	h	h1	h2	l1	l2	M	Version
	TGR6	6	0.6	1.9	2.5	17.0	0.6	0.8	10	2.5	4	S2
	TGR8	8	0.6	1.9	3	22.0	0.6	1.1	13	3.25	4	S2
				0.8	2.1							
	TGR10	10	0.8	2.2	4	22.0	0.8	1.2	12	4	5	S2
				1.2	2.6							
				1.6	3.0							
	TGR12	12	1.2	2.6	5	22.0	0.8	1.4	11	5	5	S2
				1.6	3.0							
				2.0	3.4							
	TGR14	14	1.6	3.0	6	22.0	0.8	1.6	10	6	6	S2
				2.0	3.4							
				2.4	3.8							
				2.8	4.2							

➔ Beispiel Bestellbezeichnung · Example of order specification · Esempio codice di ordinazione: **TGR6-06-S2**

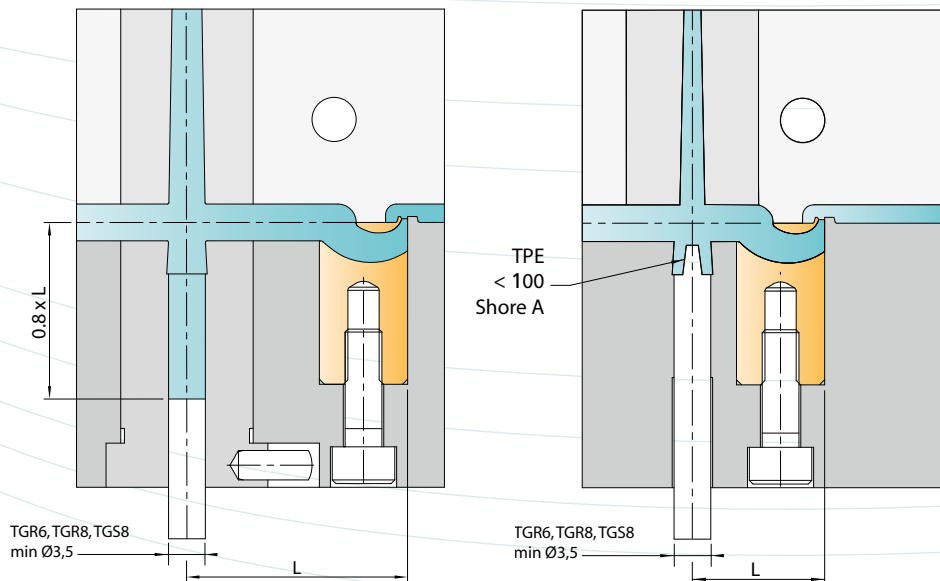

- DE Thermoplastische Elastomere (TPE)**
 - > Kleine Shorehärte = geringeres Abstandsmaß L
 - > Zentrierzapfen verwenden
 - > Shorehärte max. 100 Shore A
- EN Thermoplastic elastomers (TPE)**
 - > Low Shore hardness = shorter distance L
 - > Use centring pin
 - > Max. hardness 100 Shore A
- IT Elastomeri termoplastici (TPE)**
 - > Bassa durezza Shore = distanza L più ridotta
 - > Utilizzare un perno di guida
 - > Durezza: max. 100 Shore A

Diagramm für Abstandsmaß L · Table for distance L · Diagramma per la distanza L

	Materialart · Material type · Tipo di materiale			
	TPE, TPU etc.	PE, PP, PET etc.	PC/ABS, PA, POM, HI-PC etc.	PA+GF, PC, SAN, PMMA, etc.
TGR 6	9-12	12-18	15-22	18-25
TGR/TGS 8	11-14	15-22	19-27	23-30
TGR/TGS 10	15-18	19-27	24-33	28-36
TGR/TGS 12	18-22	22-30	27-36	32-40
TGR/TGS 14	20-25	25-33	30-37	35-43

Empfehlungen · Recommendations · Consigli

Gegenkalotte Companion vestige / Controcalotta	Flache Teile Flat parts / Pezzi piatti
---	---

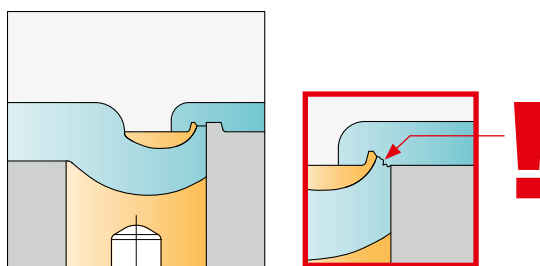

DE Um ein optimales Abreißen des Anschnittes zu gewährleisten (insbesondere bei flachen Teilen) empfehlen wir im Bereich der Kalotte mit Abrisskante eine Gegenkalotte vorzusehen. Diese gewährleistet ein Abreißen parallel zur Trennebene. Besonders bei Materialien zu empfehlen, die zu Fadenzug neigen.

EN For optimum degating (especially of flat parts), we recommend the use of a companion vestige supplementing the vestige with cutting edge. This configuration will ensure that the part is separated from the runner flush with the parting line. Users will find this particularly advantageous in cases where materials are susceptible to stringing.

IT Per garantire un ottimale distacco del punto d'iniezione (soprattutto con pezzi piatti) è consigliabile l'impiego di una controcalotta nella zona della calotta con bordo di distacco. In questo modo si garantisce un distacco parallelo alla linea di giunzione. Questo metodo è consigliabile soprattutto per i materiali che tendono a sfilacciarsi.

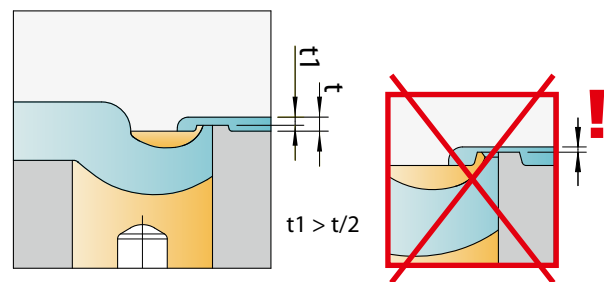

DE Bei sehr dünnen Teilen muss die Kalotte abgeschliffen werden. ($t_1 > t_2$)

EN If the molded part is very thin, the calotte must be ground down. ($t_1 > t_2$)

IT Per la realizzazione di pezzi molto sottili è necessario rettificare la calotta. ($t_1 > t_2$)

Einbaubeispiele

Examples of installation · Esempi di montaggio

unter Wand / under wall / sotto parete

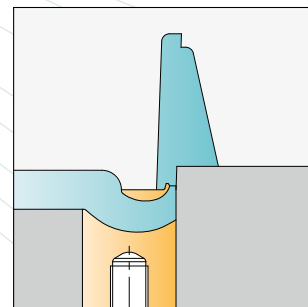
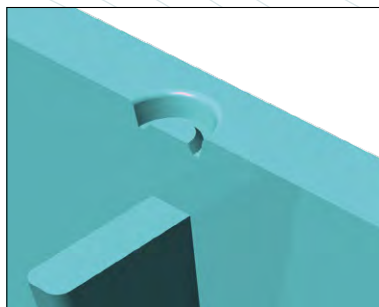
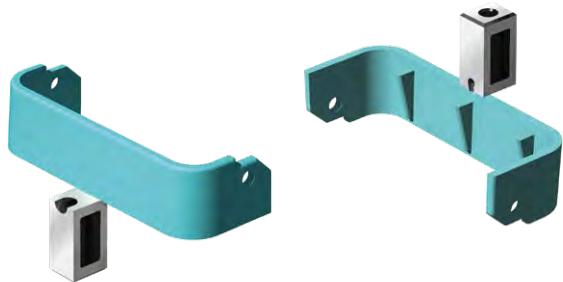

mit Fließhilfe / with flow promoter / con fluidificante

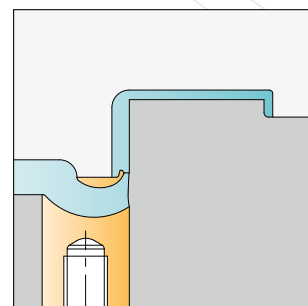
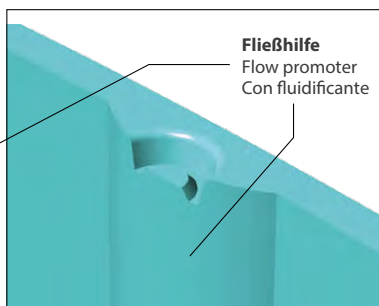
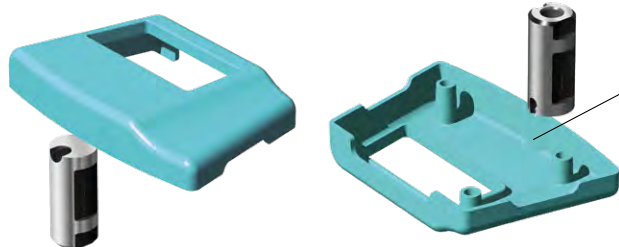

angepasst an Kunststoffteil / adapted to part / adattato al pezzo

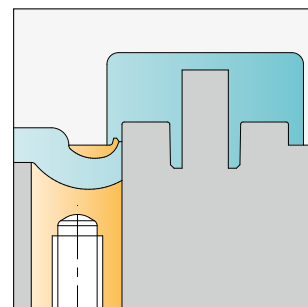
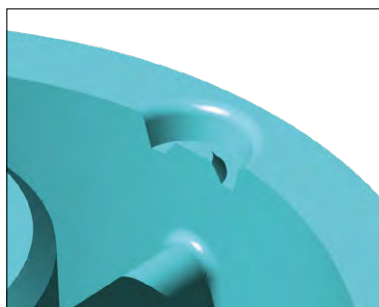

flaches Teil mit Gegenkalotte – Einbau in Düsenseite

flat part with companion vestige – installation in fixed half of the mold
pezzo piatto con controcalotta – montaggio nel lato ugello

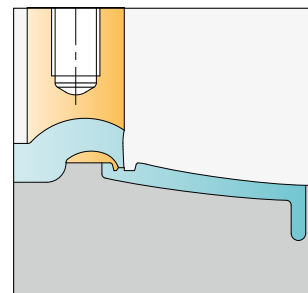
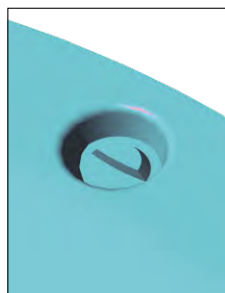

flaches Teil ohne Gegenkalotte

flat part without companion vestige
pezzo piatto senza controcalotta

DE wenn kein 100%iger Abriss gefordert ist oder verstärkte Kunststoffe verwendet werden, kann bei flachen Teilen ohne Gegenkalotte gearbeitet werden. (siehe Seite 9).

EN If a 100% clean separation of the sprue is not necessary or if reinforced plastics are being processed, the use of a companion vestige may be waived when molding flat parts. (see page 9).

IT la controcalotta non è necessaria se non è richiesto un distacco al 100% oppure se vengono impiegate plastiche rinforzate. (Vedasi pagina 9).

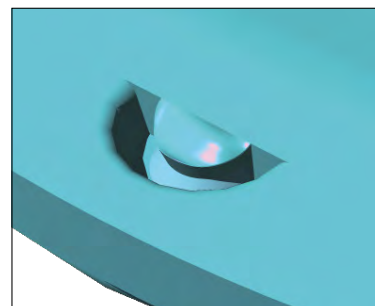

TGR TGS S1

mit Aufmaß
with machining allowance
con tolleranza dimensionale

Geeignet für alle Kunststoffe · Suitable for all plastics · Adatto per ogni tipo di plastica

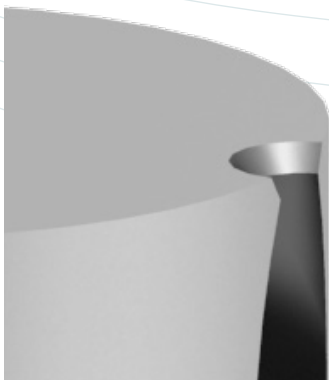

- DE** > mit Aufmaß an der oberen Fläche
> leichte Konturierungen möglich
> gleiche Eigenschaften wie Version S2
> erhältlich in runder (TGR) und eckiger (TGS) Ausführung

- EN** > with machining allowance on upper surface
> slight contourings possible
> same properties as version S2
> available in round (TGR) and square (TGS) versions

- IT** > con tolleranza dimensionale sulla superficie superiore
> consente semplici contornature
> caratteristiche identiche a quelle della versione S2
> disponibile in versione tonda (TGR) e squadrata (TGS)

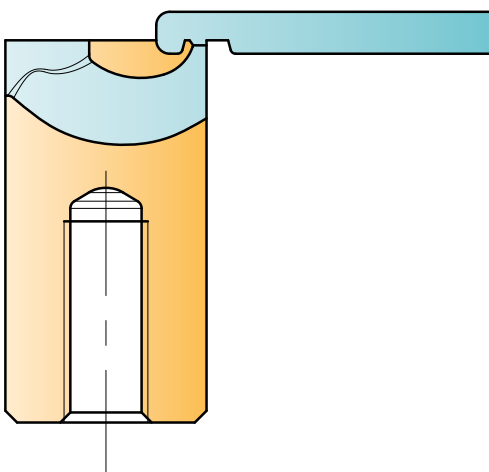

	TGR 6	TGR/TGS 8	TGR/TGS 10	TGR/TGS 12	TGR/TGS 14
 Anschnitt / gate point / punto d'iniezione	0,6	0,6 / 0,8	0,8 / 1,2 / 1,6	1,2 / 1,6 / 2,0	1,6 / 2,0 / 2,4 / 2,8
Ø Kanal / runner / canale	2,5	3	4	5	6
max. Schussgewichte (g) · max. shotweight (g) · pesi d'iniezione max. (g)					
NV	3	5	30	50	200
MV	2	4	20	35	120
HV	1	3	12	25	75

NV = niedrige Viskosität / low viscosity / bassa viscosità
MV = mittlere Viskosität / medium viscosity / media viscosità
HV = hohe Viskosität / high viscosity / elevata viscosità

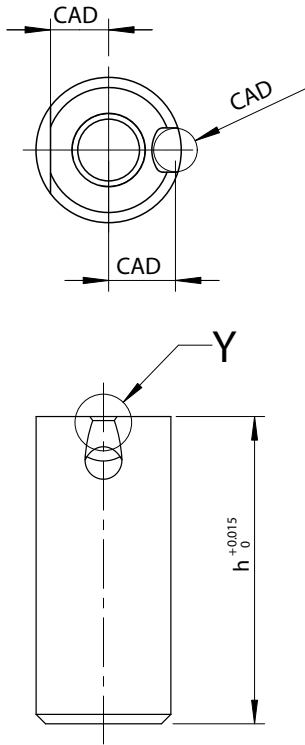

Mögliche Verdrehsicherung
Anti-rotation locking possibility
Possibilità di protezione antitorsione

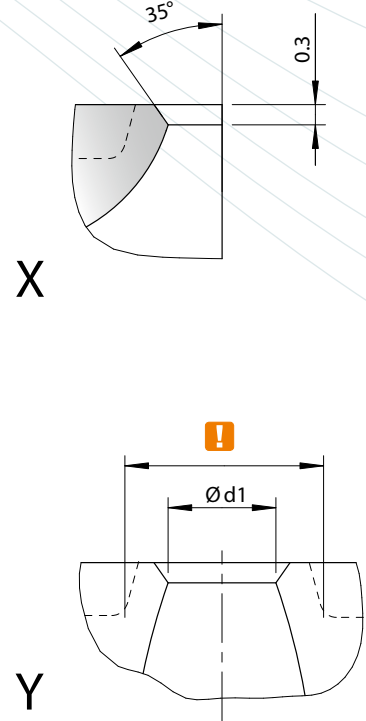
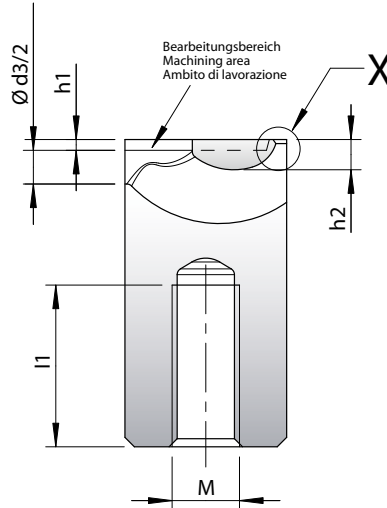

! Mindestgröße der Kalotte wie bei S2
Minimum size of vestige same as version S2
Dimensioni minime della calotta come per la versione S2

TGS	Typ	b	b1	d1	d3	h	h1	h2	l1	l2	M	Version
	TGS8	8	6	0.6	3	22.6	0.6	1.7	13	3.25	4	S1
	TGS10	10	8	0.8	4	22.8	0.8	2.0	12	4	5	S1
				1.2								
				1.6								
TGS12	12	10	1.2	5	22.8	0.8	2.2	11	5	5	S1	
			1.6									
			2.0									
TGS14	14	12	1.6	6	22.8	0.8	2.4	10	6	6	S1	
			2.0									
			2.4									
			2.8									

TGR	Typ	d	d1	d3	h	h1	h2	l1	l2	M	Version
	TGR6	6	0.6	2.5	17.6	0.6	1.4	10	2.5	4	S1
	TGR8	8	0.6	3	22.6	0.6	1.7	13	3.25	4	S1
			0.8								
	TGR10	10	0.8	4	22.8	0.8	2.0	12	4	5	S1
1.2											
1.6											
TGR12	12	1.2	5	22.8	0.8	2.2	11	5	5	S1	
											1.6
											2.0
TGR14	14	1.6	6	22.8	0.8	2.4	10	6	6	S1	
											2.0
											2.4
											2.8

➔ Beispiel Bestellbezeichnung · Example of order specification · Esempio codice di ordinazione: **TGR6-06-S1**

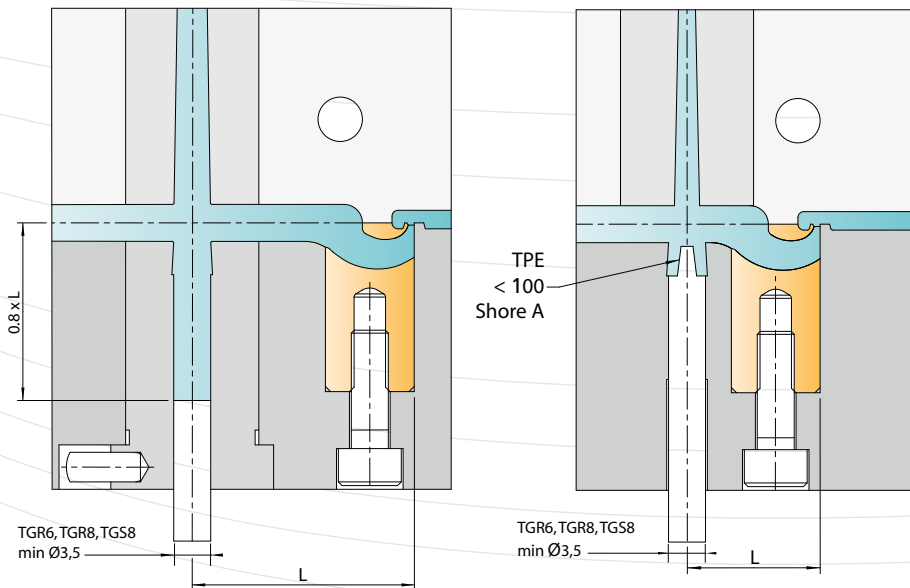

DE Thermoplastische Elastomere (TPE)

- > Kleine Shorehärte = geringeres Abstandsmaß L
- > Zentrierzapfen verwenden
- > Shorehärte max. 100 Shore A

EN Thermoplastic elastomers (TPE)

- > Low Shore hardness = shorter distance L
- > Use centring pin
- > Max. hardness 100 Shore A

IT Elastomeri termoplastici (TPE)

- > Bassa durezza Shore = distanza L più ridotta
- > Utilizzare un perno di guida
- > Durezza: max. 100 Shore A

TGR / TGS S1

Diagramm für Abstandsmaß L · Table for distance L · Diagramma per la distanza L

	Materialart · Material type · Tipo di materiale			
	TPE, TPU etc.	PE, PP, PET etc.	PC/ABS, PA, POM, HI-PC etc.	PA+GF, PC, SAN, PMMA etc.
TGR 6	9-12	12-18	15-22	18-25
TGR/TGS 8	11-14	15-22	19-27	23-30
TGR/TGS 10	15-18	19-27	24-33	28-36
TGR/TGS 12	18-22	22-30	27-36	32-40
TGR/TGS 14	20-25	25-33	30-37	35-43

Empfehlungen · Recommendations · Consigli

Gegenkalotte
Companion vestige / Controcalotta

Flache Teile
Flat parts / Pezzi piatti

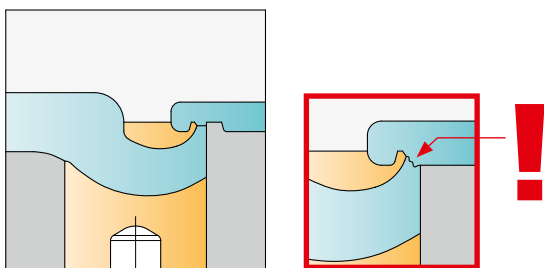

DE Um ein optimales Abreißen des Anschnittes zu gewährleisten (insbesondere bei flachen Teilen) empfehlen wir im Bereich der Kalotte mit Abrisskante eine Gegenkalotte vorzusehen. Diese gewährleistet ein Abreißen parallel zur Trennebene. Besonders bei Materialien zu empfehlen, die zu Fadenzug neigen.

EN For optimum degating (especially of flat parts), we recommend the use of a companion vestige supplementing the vestige with cutting edge. This configuration will ensure that the part is separated from the runner flush with the parting line. Users will find this particularly advantageous in cases where materials are susceptible to stringing.

IT Per garantire un ottimale distacco del punto d'iniezione (soprattutto con pezzi piatti) è consigliabile l'impiego di una controcalotta nella zona della calotta con bordo di distacco. In questo modo si garantisce un distacco parallelo alla linea di giunzione. Questo metodo è consigliabile soprattutto per i materiali che tendono a sfilacciarsi.

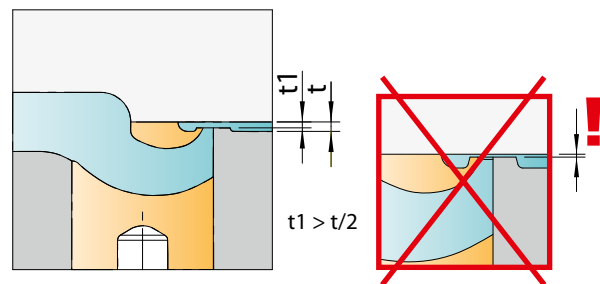

DE Bei sehr dünnen Teilen muss die Kalotte abgeschliffen werden. ($t_1 > t/2$)

EN If the molded part is very thin, the calotte must be ground down. ($t_1 > t/2$)

IT Per la realizzazione di pezzi molto sottili è necessario rettificare la calotta. ($t_1 > t/2$)

Einbaubeispiele

Examples of installation · Esempi di montaggio

abgerundete Kante / rounded edge / bordo arrotondato

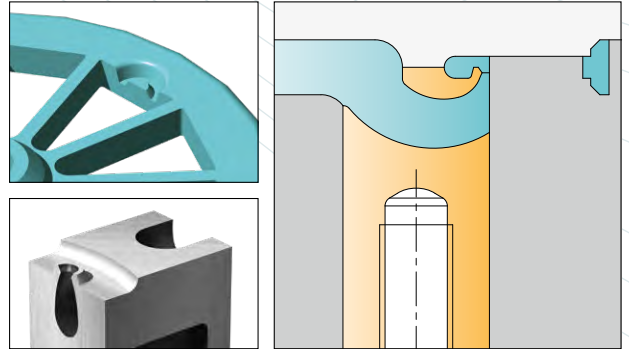

mit Fließhilfe / with flow promoter / con fluidificante

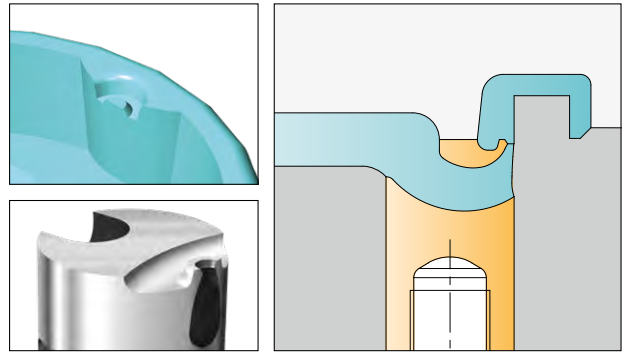

gewölbte Trennung / rounded separation / separazione bombata

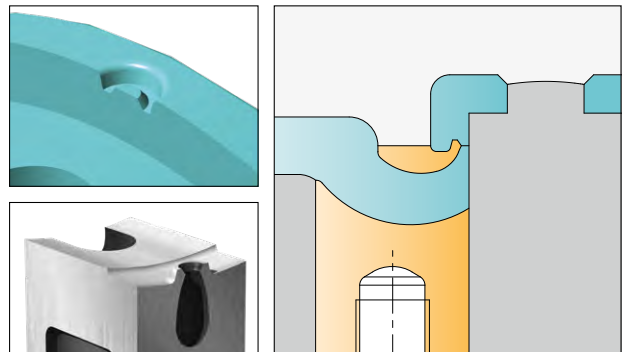

flach mit Gegenkalotte / flat, with companion vestige / piatto, con controcalotta

