

Filter Nozzle

HEATLOCK



Filter Nozzle

A filter nozzle helps by removing metal shavings and impurities in the plastic material. In this way you avoid blockages in your hot runner system which could force a production stop for cleaning.

Moreover the plastic material is mixed better before it is injected into the form, which helps you to keep an even and high quality in the production.

By using the filter nozzle you will save both time and money.

- M1 has a toothed surface on the filter which gives it very good mixing properties.
- M2 is the simplest to clean since it has a smooth surface on the filter.
- M3, which is provided with a needle point, is capable of limiting the build up of threading. In the use of a pin-point intake nozzle together with, for example crystal-line plastic this is very desirable.

All models are produced in SKD-61 and are also TIN-treated.

The body is made in a number of standard forms and can also be ordered in a special design.

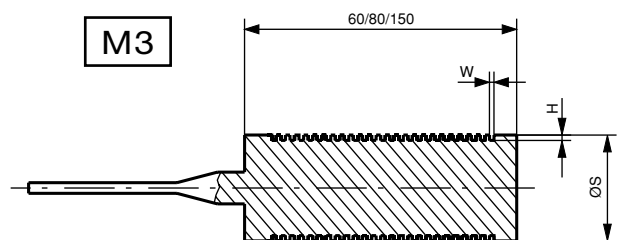
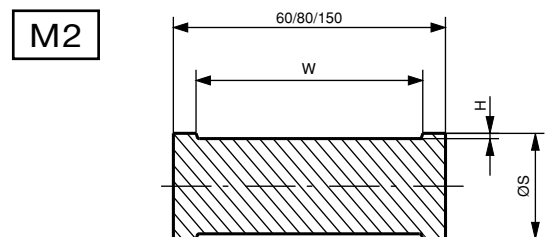
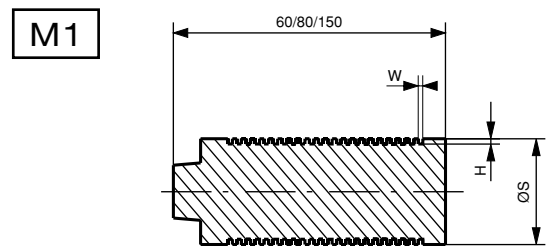

Order Form

N40

For shot weight < 1000g. Corresponds to a machine size up to approx. 400 ton.

N50

For shot weight < 5000g. Corresponds to a machine size between 400 ton to 1000 ton.

When ordering:

Fill out the form below and specify your nozzle. This form also available as PDF at www.heatlock.com

Fax this sheet to us: (86)0769-8382 5600

Company	
Name	
Address	
Phone	
Fax	
Email	
Qty	
Notes by Heatlock	

Nozzle	M1		M2		M3	
H	0.8	1.5	0.8	0.8	1.5	1.5
W	0.8	1.5	50	0.8	1.5	1.5
d2	S20			S15		

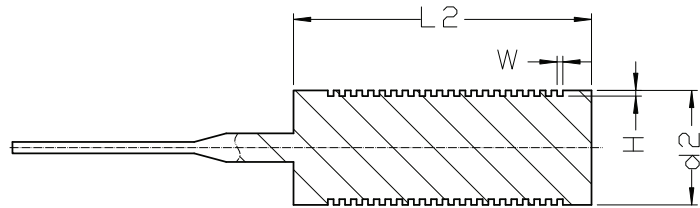
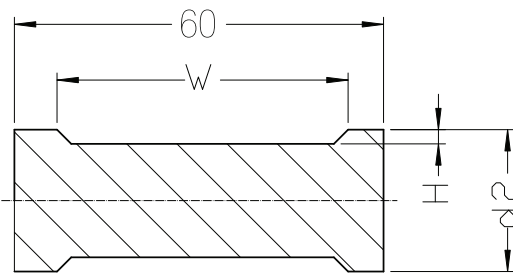
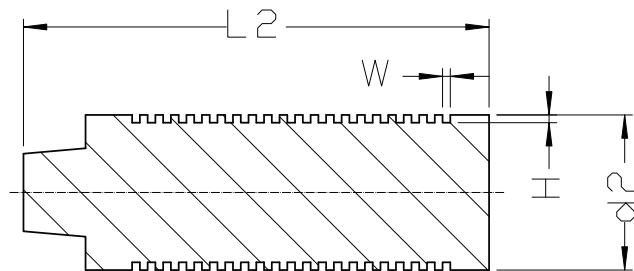
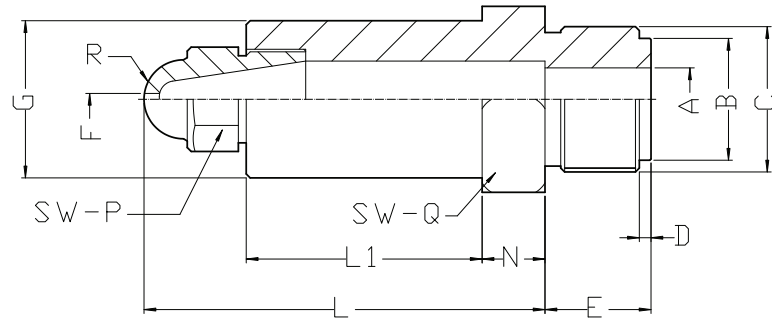
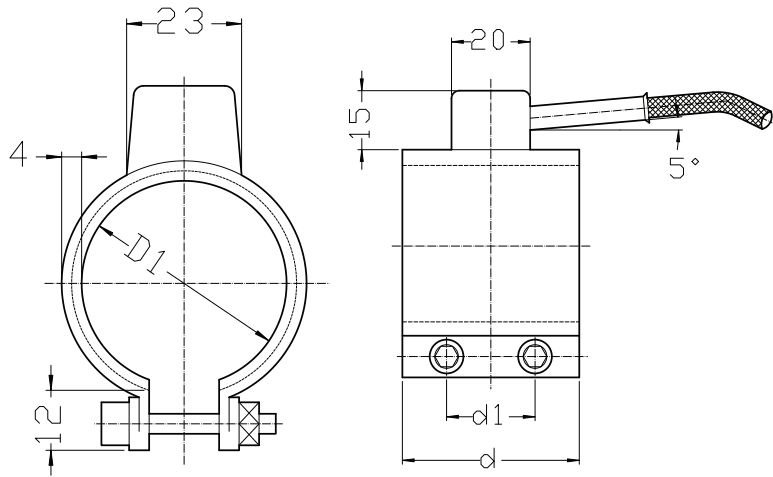

When ordering, please write down the following dimension:

Type	A	B	C	D	E	L	F	G	L1	N	R	SW-P	SW-Q
N40							3	40	70	16	10	23	41
N50							3	50	90	20	13	29	54

*N40: L=112, L1=70, A max.=18

(including coil heater : B040045250, D1=40, d=45, d1=22.5, G=40)

*N50: L=142, L1=100, A max.=28

(including coil heater : B050060420, D1=50, d=60, d1=30, G=50)

中国广东省东莞市常平镇站前路(南段)志兴商务大厦B座506室
Room 506, Block B, ZhiXing International Building, South ZhanQian Road
ChangPingTown, DongGong, PRC. 邮编 Zip Code : 523560
电话 Tel : (86) 0769-8382 5600 传真 Fax : (86) 0759-8382 5626
电子邮箱 E-mail : frontdesk@heatlock.com

14th Floor South China Building, 1-3 Wyndham Street Central, Hong Kong
电话 Tel : (852) 8120 5469
传真 Fax : (852) 2653 5230
电子邮箱 E-mail : frontdesk@heatlock.com